

EST.
1877

ZEST



Silver Cross[®]

THE BEST START IN LIFE

**IMPORTANT: KEEP THESE INSTRUCTIONS
FOR FUTURE REFERENCE**

1.1



These instructions are important.

Read these instructions carefully before use and keep them for future reference. Your child's safety may be affected if you do not follow these instructions. Your Zest pushchair is a high quality Silver Cross product. It meets current safety standards and care and regular light maintenance will ensure long service. This vehicle is intended for children from birth to 25kg. If somebody unfamiliar is using your Zest pushchair always ensure that they read these instructions carefully so that they understand how the product works best. Always read all the instructions provided carefully and remember, the safety of your child is your responsibility.

WARNING: Never leave your child unattended.

Contents

Your Zest pushchair includes the following components, please check that you have all the items before proceeding:

- 1.1 Zest Pushchair Chassis, Seat Fabrics and Basket
- 1.2 Zest Hood
- 1.3 Zest Raincover
- 1.4 Zest Front Wheel Assembly x2

1.2

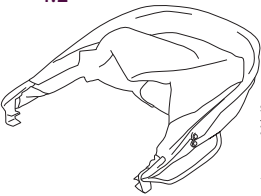

1.3



1.4

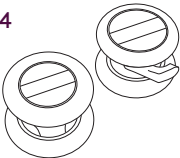

2.1

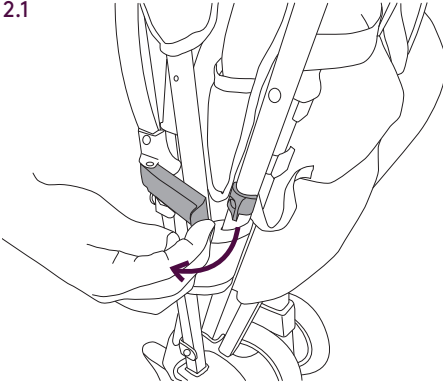

Assembling the Zest

WARNING: Check the wheel is secure by pulling gently downwards.

Repeat on both sides. Your Zest is now ready to be unfolded.

- 2.1 Locate the locking catch on the side of the pushchair and lift to release from the locking stud.
- 2.2 Allow the pushchair to open by lifting the handles upwards and the wheels will naturally fall to the floor.

2.2

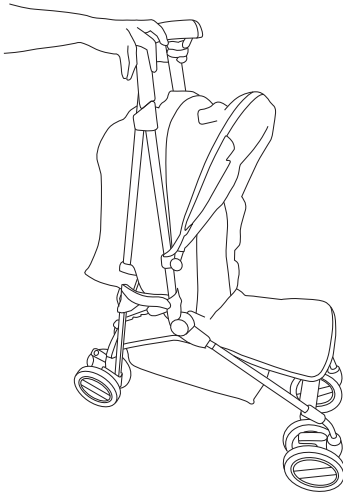

2.3

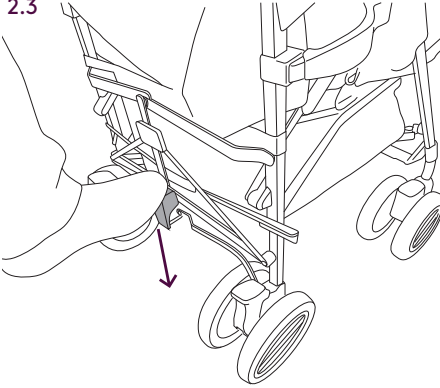

Assembling the Zest (continued)

- 2.3 Finally, press down gently upon the rear locking catch, positioned between the rear wheels, to lock your pushchair.

WARNING: Failure to do this will cause damage to your pushchair.

Place the pushchair on a flat surface and ensure that the pushchair moves freely.

2.4

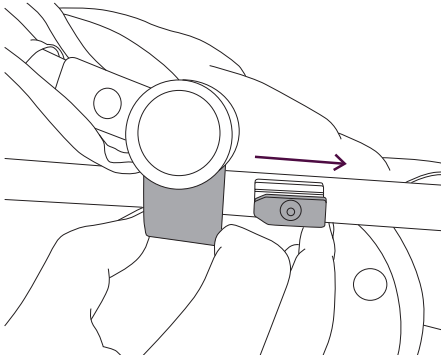

- 2.4 To fit your Zest hood, locate the clips on the hood. Now attach the hood to the Zest chassis by sliding clips over the hood connection bracket. A positive engagement should be ensured.

- 2.5 Connect the fabric of the hood to the fabric of the seat with two press studs, one on each side of the pushchair.

- 2.6 Connect the fabric of the hood to the rear leg of the chassis with two press studs, one on each side of the pushchair.

2.5

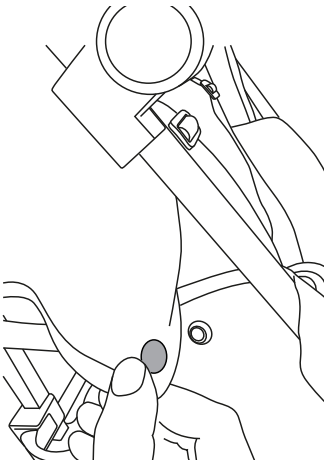

2.6

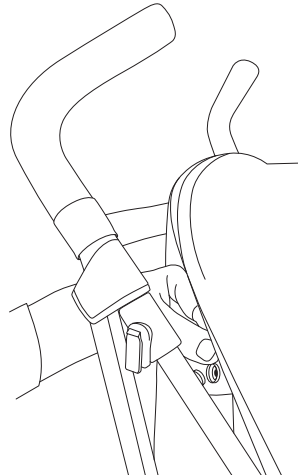

2.7

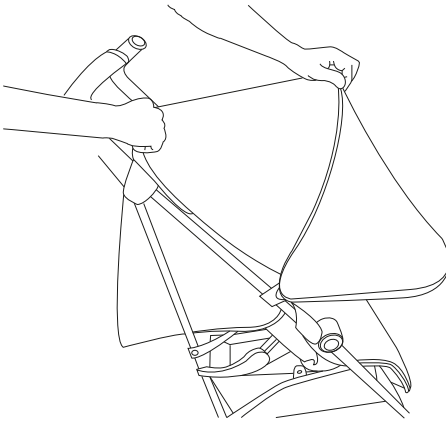
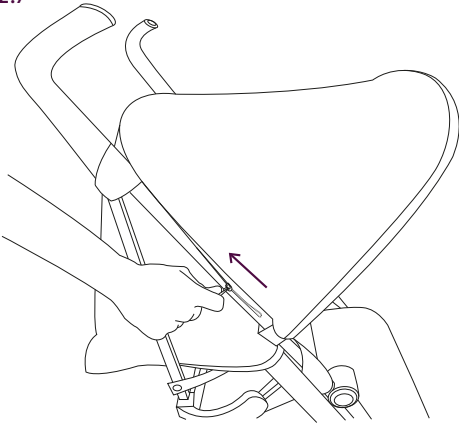

2.8

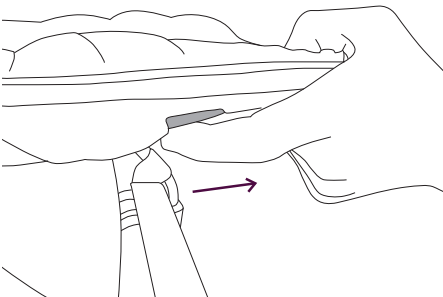

Assembling the Zest (continued)

2.7 Your Zest hood can be opened and folded by pulling the hood forward or pushing backwards on the hood frame. Your hood can also be extended forwards by unzipping zip as shown in diagram 2.7. Please note when folding your Zest pushchair you should always ensure the hood is folded away. Failure to do this could result in damage to your Zest pushchair.

2.8 Your Zest pushchair has a multi-position calf support. Locate the adjustment levers either side of the calf support. Pull levers towards you and adjust to the required position.

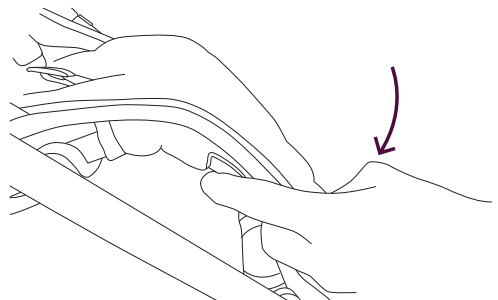

3.1

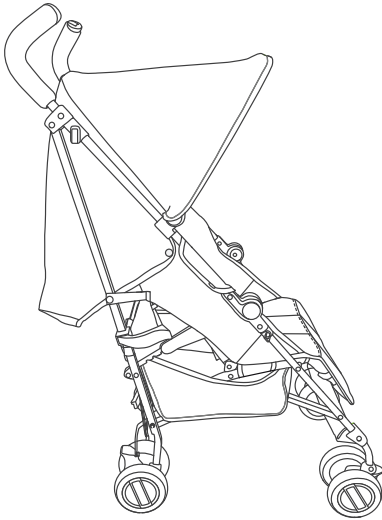

Reclining the Zest

- 3.1 Your Zest pushchair has a multi-position recline.
- 3.2 First, locate the backrest adjustment mechanism at the rear of the seat. Pull up the recline lever and gently lower to the desired position.
- 3.3 To raise the backrest locate the recline lever and pull up gently into the desired position. The backrest will rise to the desired height.

NOTE: The backrest should always be in the upright position and the hood folded away prior to folding.

3.2

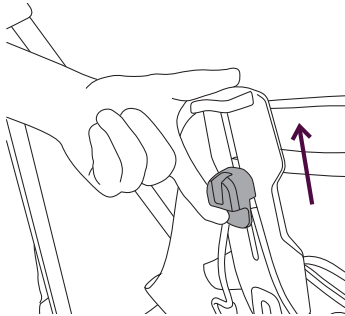

3.3

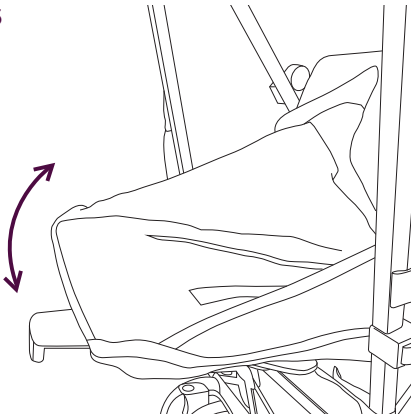

4.1

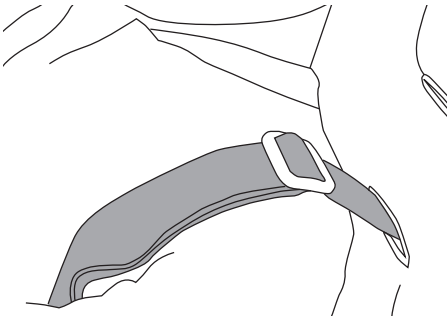

Using the Harness

The harness is a five point system consisting of shoulder straps, waist straps and crotch strap. Before you use the pushchair, the harness must be adjusted to suit the size of the child.

- 4.1** It is very important that you make sure the shoulder straps are the correct height for your child. The shoulder straps should be level or just below your child's shoulders.

In a safe and secure environment, place your child in the pushchair with the backrest upright and assess which of the three shoulder strap height positions is most suitable for your child.

NOTE: Winter/Summer clothing can make a difference to the size of your child.

WARNING: NEVER LEAVE YOUR CHILD UNATTENDED DURING THIS PROCESS. Remove your child whilst the following adjustments are being made.

5.1

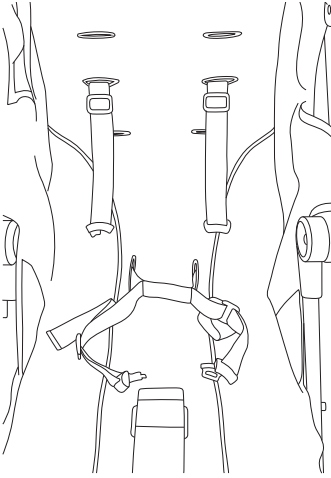

5.2

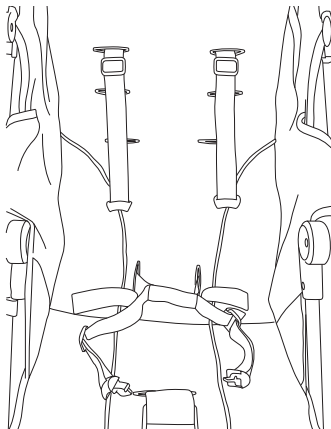
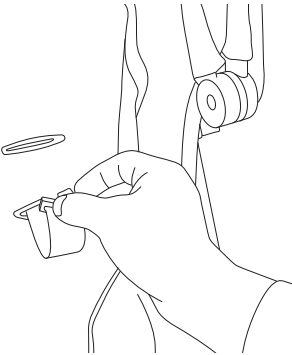

Adjusting the harness

- 5.1 Your Zest pushchair has a multi-position height adjustment for the harness. To adjust the shoulder strap height, start by disconnecting the shoulder clips from the waist clips.
- 5.2 Pass one of the shoulder clips through the button hole on the cover and backrest. Once the clip is fully through to the opposite side of the backrest, pass it back through the desired slot. Repeat these steps for the other shoulder clip, ensuring that the selected button holes are in line.

6.1

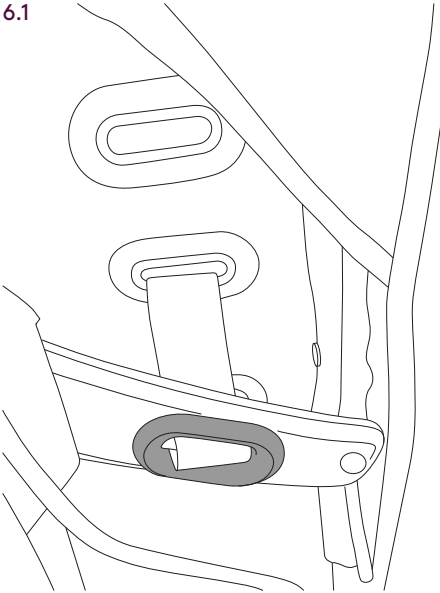

Adjusting the harness

WARNING: Always ensure plastic toggles on shoulder and waist straps are securely and correctly located into backrest.

- 6.1 Plastic toggles must always be located correctly into backrest. They do not need to be removed to adjust harness.
- 6.2 If, for any reason, toggles are removed, they can be re-located by pushing into the hole on the backrest, ensuring 2 prongs click into place securely.

6.2

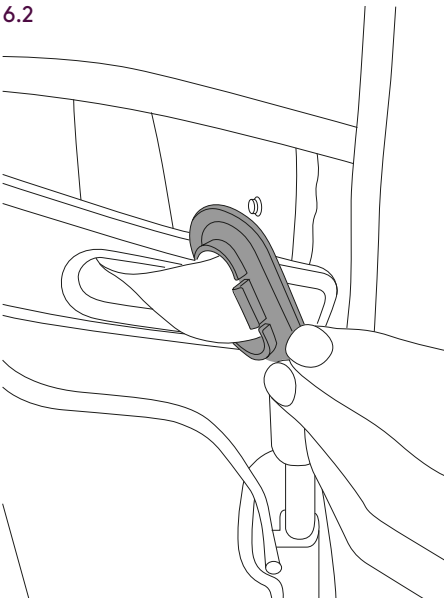

7.1

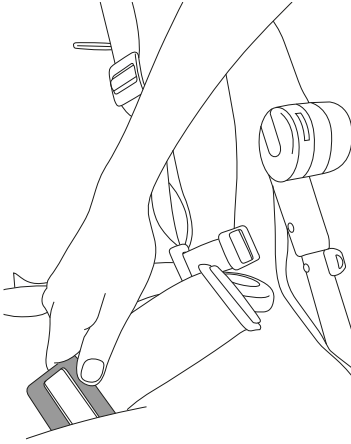

7.2

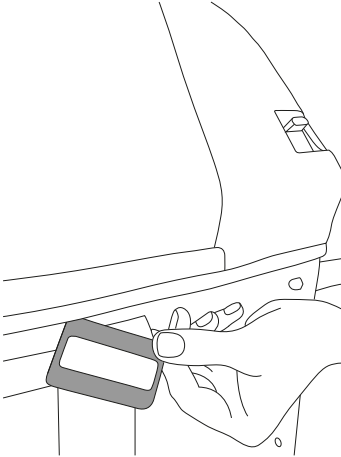

7.3

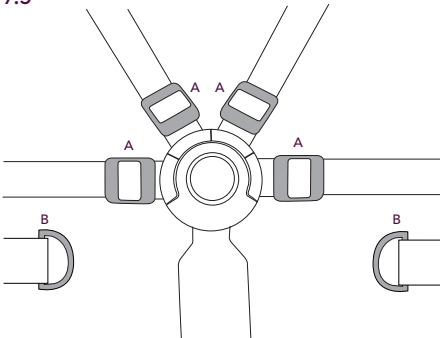

Adjusting the harness

WARNING: Always ensure buckle toggle is securely and correctly located into seat.

Buckle strap must always be located correctly into seat. It does not need to be removed to adjust harness.

- 7.1 If, for any reason, the buckle strap is removed, it can be re-located by pushing through both the buttonhole on seat fabric and buttonhole on seat substructure.
- 7.2 Ensure the buckle strap goes through both layers of fabrics.
- 7.3 Your harness is fully adjustable by moving the sliders (A), to make fitting easy. Normally, each shoulder strap is adjusted to the same length as the waist straps.

'D' rings are provided for fitting a separate harness if required (B), complying with BS 6684. Your child should always be harnessed in and should never be left unattended, even for short periods of time.

8.1

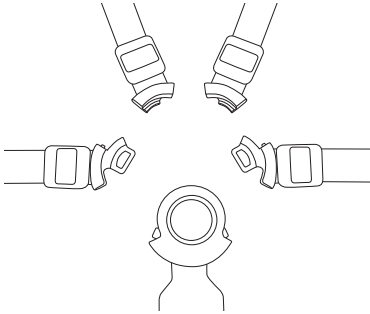

8.2

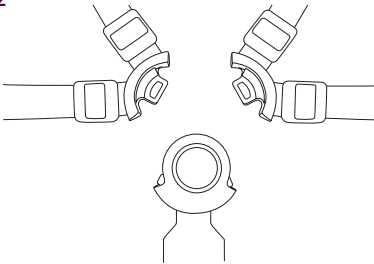

8.3

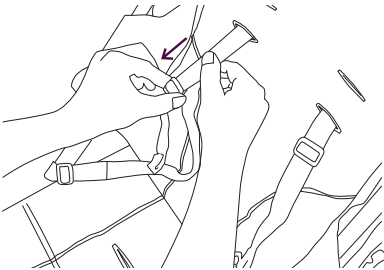

8.4

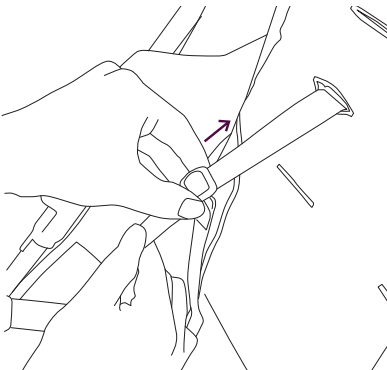

Using the harness

Attach and release the buckle as necessary to facilitate harness adjustment and checking the harness tightness.

WARNING: Always use the crotch strap in combination with the waist belt.

- 8.1 Start by connecting shoulder clips to waistclips.
- 8.2 To fasten the harness insert the pairs of clips into each side of the buckle. Listen for the 'click'.
- 8.3 Pull sliders in one direction to lengthen the strap
- 8.4 Pull slider in opposite direction to shorten strap

WARNING: Always use the restraint system. To release the harness, press the centre and pull apart. The shoulder clips can be detached from the waist clips if required.

9.1

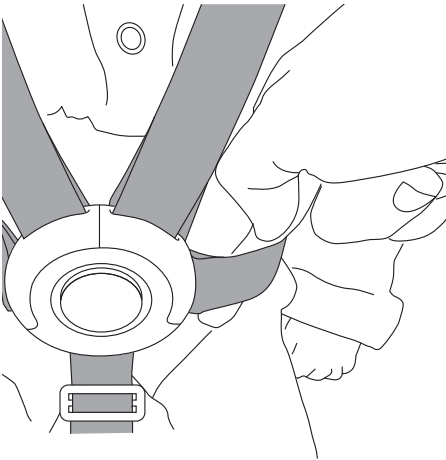
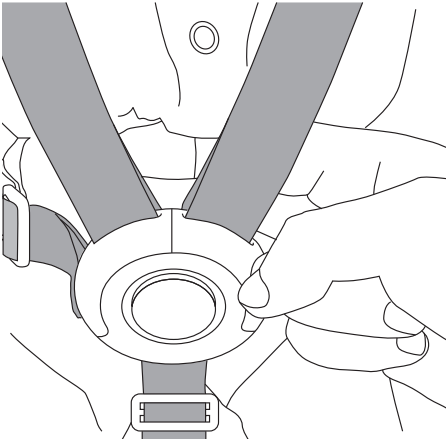

Harness tightness

It is important to ensure that your child is securely fastened into the harness by assessing the tightness of the straps.

- 9.1 You should only be able to insert 2 fingers between the shoulder straps and the waist straps.

NOTE: Winter/Summer clothing can make a difference to the size of your child.

10.1

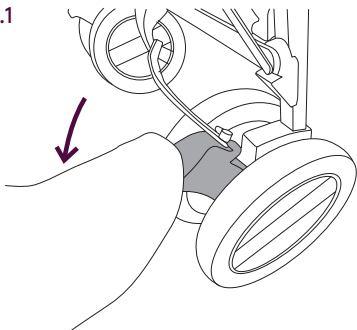

Using the brakes

- 10.1 Your Zest pushchair has a parking brake. To apply the brake simply press downwards on either brake catch located on the rear wheels. The brake will automatically lock on both wheels simultaneously.

WARNING: Ensure both brake levers are locked in position securely.

- 10.2 To release the parking brake simply lift either brake catch and both catches will release simultaneously.

NOTE: Always apply brake when placing and removing your child.

10.2

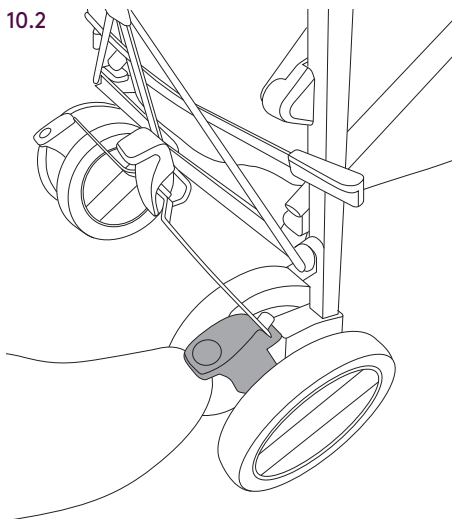

11.1

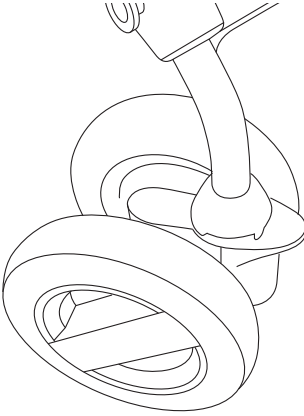

Using the wheel locks

- 11.1 Your Zest pushchair has front swivel wheels. To lock, locate the locking catch between the front wheels, pivot the wheels into the position for moving forward and lift the locking catch. To use the wheels in swivel mode, release the catch and the wheels will swivel freely. Repeat on each wheel.

NOTE: Do not attempt to swivel the wheels with the lock engaged as this may damage the swivel lock.

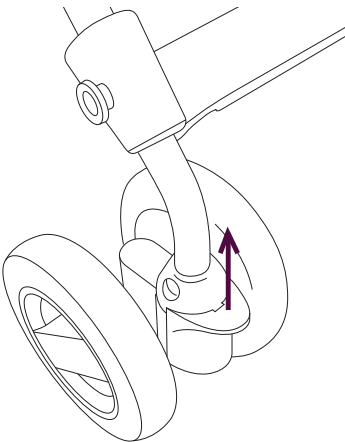
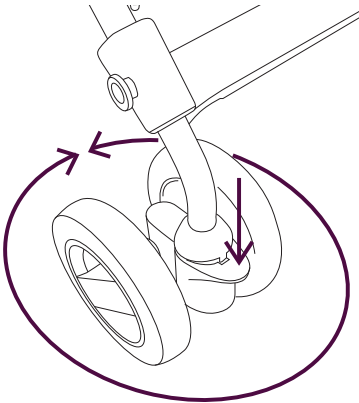

12.1

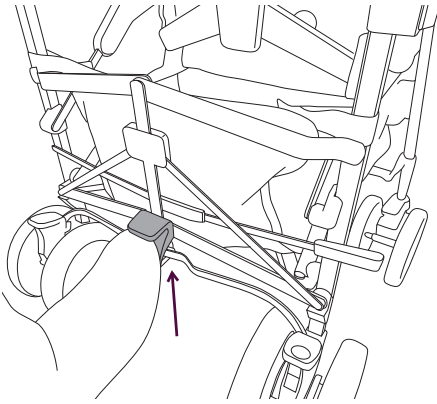

12.2

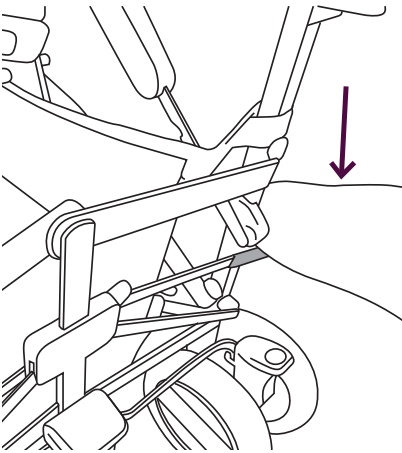

Folding the Zest

NOTE: The backrest should always be in the upright position and the hood folded away prior to folding.

12.1 To start folding, locate the rear locking catch (positioned between the rear wheels) and lift upwards with the toe of your shoe.

12.2 Now locate the secondary safety catch located above the right hand rear wheel. Gently press down until the lock has released.

NOTE: Check there are no large rigid items inside the basket before folding as presence of such items may lead to damage of the chassis.

12.3

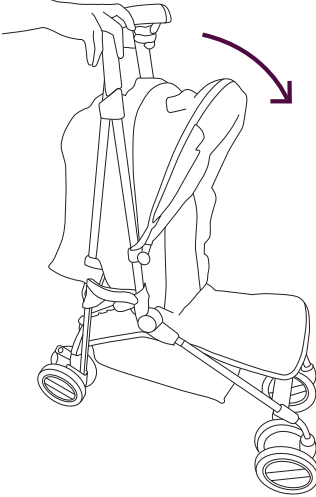

Folding the Zest (continued)

12.3 Push the handles forwards and the pushchair will naturally close in three dimensions to a compact size. Ensure the locking catch on the side of the pushchair has engaged.

12.4 Your Zest pushchair has a fabric carry strap to the rear of the stroller.

WARNING: This strap is the only position from which you should lift your pushchair to avoid possible damage.

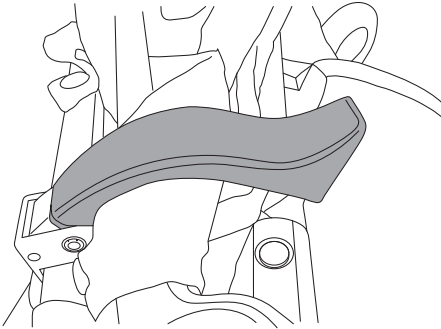

12.4

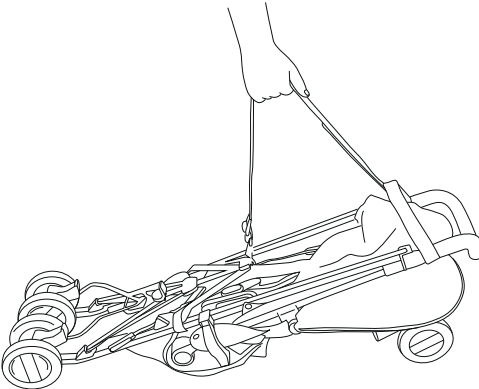

13.1

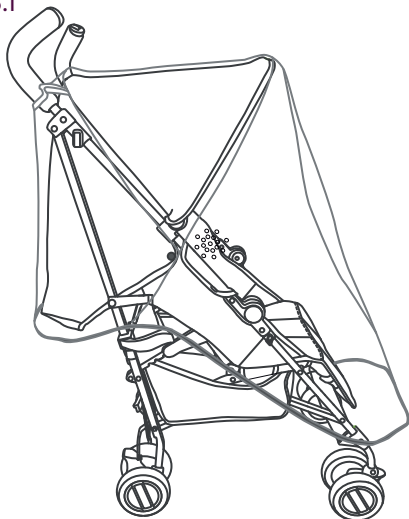

Attaching the raincover

- 13.1 To attach your raincover locate guide holes over handles, and slide the cover down over the chassis.
- 13.2 Fasten velcro handles to secure the raincover.
- 13.3 Hook elastic loops either side of raincover over plastic studs on chassis.

Pull raincover down to the bottom of the pushchair and tuck foot end under calf support.

13.2

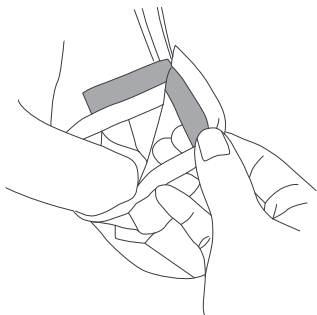

13.3

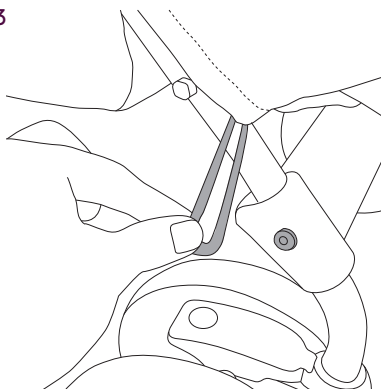

Safety Notes

This item is a high quality Silver Cross product. It complies with BS EN1888:2012 and with correct use and maintenance will give good service. If however you should have any problems with your product, please contact your Silver Cross retailer who will take appropriate action.

WARNING:

This product is suitable from birth to 25kg

It is recommended the most reclined position is used for new born babies.

Always use the restraint system.

Never leave your child unattended.

Ensure all locking devices are engaged before use.

To avoid injury ensure that your child is kept away when unfolding and folding this product.

Do not let your child play with this product.

This product is not suitable for running or skating.

Parking device shall be engaged when placing or removing the child.

Any load attached to the handle and/or the back of the backrest and/or on the side of the vehicle will affect the stability of the vehicle.

Do not carry more than one child in this pushchair.

Do not stand a second child on rear lock and use as a buggy board.

Do not attach a third party buggy board.

Accessories which are not approved by Silver Cross shall not be used.

Only replacement parts supplied/recommended by Silver Cross shall be used.

Do not use if any part is broken, torn, or missing.

The child should be clear of moving parts whilst making adjustments.

Do not allow your child to climb in or out of the pushchair of their own accord, as this could result in injury to your child or damage to your pushchair.

Never leave your child in the pushchair with the raincover fully fitted other than in normal outside use.

The safety of your child is your responsibility.

Seat unit only compatible with: Zest Chassis.

Basket capacity: 2kg

Cupholder capacity: 340g

The child should always wear a safety harness complying with BS6684. "D" rings are provided for the attachment of an additional harness. These are located on the seat unit.

Always hold the seat when making adjustments. Be sure that the parking brake is on. If you have any difficulty in folding or unfolding the pushchair do not force as this will cause damage. Read the "To fold or unfold" instructions carefully. It may be unsafe to fit accessories or spare parts other than those supplied or recommended by Silver Cross. If anyone other than the owner is going to use this product (e.g. grandparent, child minder), please show them how to use it correctly.

Care and Maintenance

Chassis - Always check your pushchair for signs of wear. Regularly lubricate all moving parts. Check for freedom of movement of all locking devices. Polish metal work with a clean, dry cloth.

Dirt and dust within moving mechanisms may be rinsed away with clean water. Do not soak or submerge.

Fabric items - Please refer to the washcare instructions on each individual item's washcare label.

Seat Unit - To clean, sponge area with warm soapy water. Rinse well with clean water to avoid staining. Allow to dry naturally, away from direct heat and strong sunlight.

Never machine wash, tumble dry, iron or bleach any of the fabric items or seat unit.

A certain degree of fading may occur over time through everyday use.

Guarantee

All Silver Cross products are guaranteed for a period of 12 months against faulty workmanship, when the product is used correctly according to the instruction manual.

Please read these instructions carefully before using your new Silver Cross Product and keep for future reference.

www.silvercrossbaby.com

Consignes de sécurité

Ce produit est appelé: Zest

Ce produit est un article Silver Cross de la plus grande qualité. Il est conforme aux normes BS EN1888:2012 et saura répondre à vos besoins s'il est utilisé et entretenu correctement. Si toutefois vous rencontrez le moindre problème avec votre poussette, veuillez contacter votre revendeur Silver Cross pour qu'il prenne les mesures adéquates.

AVERTISSEMENT:

Ce produit peut être utilisé de la naissance à 25 kg

Il est conseillé d'utiliser la position la plus inclinée pour les nouveau-nés.

Ne laissez jamais votre enfant sans surveillance.

Assurez-vous que tous les dispositifs de verrouillage sont enclenchés avant utilisation.

Pour éviter les blessures, maintenez votre enfant à l'écart lorsque vous pliez et dépliez ce produit.

Ne laissez pas votre enfant jouer avec ce produit.

Utilisez toujours le système de retenue.

Ce produit n'est pas conçu pour la course ou le patinage.

Le frein doit être actionné lorsque vous positionnez ou retirez votre enfant de la poussette

Toute charge posée sur la poignée, le dossier ou les bords de la poussette risque de compromettre sa stabilité.

Ne transportez pas plus d'un enfant sur cette poussette.

Ne laissez pas un autre enfant se tenir debout sur le système de verrouillage arrière pour vous en servir de marchepied.

N'utilisez pas de marchepied d'autre provenance avec cette poussette.

Aucun accessoire non approuvé par Silver Cross ne doit être utilisé.

N'utilisez que des pièces détachées fournies/recommandées par Silver Cross.

N'utilisez pas ce produit si l'une des pièces est endommagée, déchirée ou manquante.

Attention : Tenez les pièces mobiles hors de la portée de votre enfant lorsque vous effectuez des réglages.

Ne laissez pas votre enfant grimper tout seul dans/hors de la poussette car il pourrait se blesser ou endommager la poussette.

Ne laissez jamais votre enfant avec l'habillage pluie refermé sur la poussette ailleurs qu'à l'extérieur.

Vous êtes responsable de la sécurité de votre enfant.

Hamac uniquement compatible avec : Châssis Zest

Capacité du panier : 2 kg

L'enfant doit toujours porter un harnais de sécurité conforme à la norme BS6684. Les

anneaux en « D » sont fournis pour attacher un harnais supplémentaire. Ces anneaux sont situés sur le harnais existant, à côté du point de fixation du harnais au châssis du siège.

Tenez toujours le siège lorsque vous effectuez des réglages. Assurez-vous que le frein est actionné. Si vous rencontrez des difficultés pour plier ou déplier la poussette, ne forcez pas car vous risqueriez de l'endommager. Lisez attentivement les instructions « Pliage ou dépliage ». Ne montez pas des accessoires ou pièces de rechange autres que ceux fournis ou recommandés par Silver Cross, car cela peut être dangereux. Si une personne autre que le propriétaire utilise la poussette (par exemple : grands-parents ou nourrice), montrez-lui comment l'utiliser correctement.

Nettoyage et entretien

Châssis - vérifiez toujours que la poussette ne présente pas de traces d'usure. Lubrifiez régulièrement toutes les pièces mobiles. Vérifiez la liberté de mouvement de tous les dispositifs de verrouillage. Frottez les parties métalliques avec un chiffon propre et sec.

Parties en tissu et siège -pour nettoyer, utilisez une éponge et de l'eau chaude savonneuse. Rincez bien à l'eau claire pour ne pas laisser de taches. Laissez sécher à l'écart d'une source de chaleur directe et de la lumière intense du soleil. Les couleurs peuvent s'altérer avec le temps. Ne lavez et ne séchez jamais en machine, ne repassez jamais et n'utilisez jamais d'eau de javel.

Garantie

Tous les produits Silver Cross sont garantis pour une période de 12 mois contre tout défaut de fabrication, si le produit est utilisé conformément au manuel d'instructions.

Veillez lire ces instructions attentivement avant d'utiliser votre nouveau produit Silver Cross et veuillez les conserver pour référence ultérieure.

Norme di sicurezza

Questo prodotto si chiama: Zest

Questo articolo è un prodotto Silver Cross di alta qualità. È conforme alle norme BS EN 1888:2012 e con un uso e una manutenzione corretti garantisce un ottimo funzionamento. Se, tuttavia, si riscontrano problemi nell'utilizzo del prodotto, contattare il rivenditore Silver Cross che si adopererà per la risoluzione del problema.

AVVERTENZE:

Questo prodotto è adatto al trasporto di neonati e bambini fino a 25 Kg.

Per i neonati si raccomanda di utilizzare la posizione maggiormente reclinata.

Mai lasciare il bambino incustodito.

Accertarsi che tutti i dispositivi di bloccaggio siano inseriti prima dell'uso.

Per evitare infortuni assicurarsi che il bambino sia a debita distanza durante le operazioni di apertura e chiusura del passeggino.

Non lasciare che il bambino giochi con il prodotto.

Utilizzare sempre il sistema di ritenuta.

Il prodotto non è adatto per correre o pattinare.

Il dispositivo di stazionamento deve essere inserito quando si fa salire o scendere il bambino.

Eventuali carichi presenti sul manico e/o sul retro dello schienale, e/o sulla parte

laterale del passeggino comprometteranno la stabilità del passeggino stesso.

Non trasportare più di un bambino in questo passeggino.

Non consentire ad un secondo bambino di rimanere in piedi sul blocco posteriore e di utilizzarlo come pedana.

Non montare pedane di altre marche.

Non utilizzare accessori non approvati da Silver Cross.

Utilizzare solo parti di ricambio fornite/raccomandate da Silver Cross.

Non utilizzare in caso di parti rotte, strappate o mancanti.

Attenzione: tenere il bambino lontano dalle parti mobili durante le operazioni di regolazione.

Per evitare danni al passeggino o infortuni non permettere al bambino di salire e scendere da solo dal passeggino.

Non lasciare mai il bambino nel passeggino con il parapigioggia completamente montato, se non durante il normale impiego all'aperto.

La sicurezza del bambino è responsabilità dell'adulto.

La seduta è compatibile solo con: Telaio Zest

Portata cesto: 2 kg

Il bambino deve sempre indossare l'imbracatura in conformità alla norma BS6684. Gli anelli a 'D' sono forniti per il fissaggio di una ulteriore imbracatura. Essi sono posizionati sull'imbracatura già presente accanto al punto di fissaggio sulla base della seduta.

Tenere sempre la seduta durante le operazioni di regolazione. Accertarsi che il dispositivo di stazionamento sia inserito. In caso di problemi nel chiudere o aprire il passeggino, non forzare, onde evitare danni. Leggere attentamente le indicazioni sull'apertura e la chiusura del passeggino. Potrebbe essere pericoloso montare parti di ricambio o accessori diversi da quelli forniti o raccomandati da Silver Cross. Se il prodotto viene utilizzato da soggetti diversi dal proprietario (ad es. nonno, baby-sitter), illustrare loro l'uso corretto.

Cura e manutenzione

Telaio: verificare sempre che sul passeggino non siano presenti segni di usura. Lubrificare regolarmente tutte le parti mobili. Verificare che i dispositivi di bloccaggio funzionino correttamente. Lucidare le parti in metallo con un panno pulito ed asciutto.

Tessuti e seduta: pulire con una spugna imbevuta di acqua tiepida e sapone. Risciacquare bene con acqua pulita per evitare di macchiare il tessuto. Lasciar asciugare, lontano da fonti di calore e dalla luce diretta del sole. Con l'uso quotidiano, il tessuto può scolorire nel corso del tempo. Non lavare in lavatrice, non utilizzare asciugabiancheria, non stirare e non candeggiare.

Garanzia

Tutti i prodotti Silver Cross sono garantiti per un periodo di 12 mesi contro difetti di fabbricazione, purché il prodotto venga utilizzato correttamente, in conformità al manuale delle istruzioni.

Leggere attentamente le istruzioni prima di utilizzare il nuovo prodotto Silver Cross e conservarle per future consultazioni.

Notas de seguridad

Este producto se llama: Zest

Este artículo es un producto de gran calidad de Silver Cross. Cumple las normativas EN1888:2012 y si lo utiliza adecuadamente y realiza un buen mantenimiento, le proporcionará un servicio excelente. No obstante, si tiene algún problema con su producto, póngase en contacto con el minorista Silver Cross, quien se encargará apropiadamente del asunto.

ADVERTENCIA:

Este producto es adecuado desde el nacimiento hasta los 25 kg

Se recomienda utilizar la posición más reclinada para los recién nacidos.

Nunca deje al niño desatendido.

Antes de utilizar la silla, compruebe que todos los dispositivos de bloqueo están correctamente accionados.

Para evitar lesiones, asegúrese de que el niño no esté cerca cuando pliegue y despliegue este producto.

No deje que el niño juegue con este producto.

Utilice siempre el arnés proporcionado.

Este producto no es adecuado para correr ni patinar.

dispositivo de estacionamiento debe estar accionado al colocar y levantar al niño de la silla.

Los pesos que se cuelguen del manillar y/o respaldo y/o laterales del vehículo afectarán a su estabilidad.

No lleve más de un niño en el cochecito.

No sitúe a un segundo niño en la protección trasera como si fuera un patinete acoplado.

No utilice patinetes acoplados de otros fabricantes.

No deben utilizarse accesorios no autorizados por Silver Cross.

Solo deben usarse piezas de recambio y accesorios autorizados por Silver Cross.

No utilice la silla si está rota o le falta alguna pieza.

Cuidado: A la hora de realizar ajustes, hay que mantener al niño lejos de piezas móviles.

No deje que el niño baje o suba de la silla él solo, ya que podría resultar herido o provocar daños a la silla.

Nunca deje al niño en la sillita con la capota puesta, salvo para su uso normal en exteriores.

Usted es responsable de la seguridad del bebé.

Asiento compatible únicamente con: Zest Chasis

Capacidad de la cesta: 2 kg

El niño debe llevar siempre abrochado un arnés de seguridad que cumpla la normativa BS6684. Se proporcionan anillas para sujetar otro arnés. Estas están situadas en el arnés existente, cerca del lugar donde está sujeto al armazón del asiento.

Sujete siempre el asiento cuando haga ajustes. Compruebe que la silla tiene accionado el dispositivo de estacionamiento. Si tiene dificultades para plegar o desplegar la silla, no ejerza fuerza o la dañará. Lea detenidamente las instrucciones «Para plegar y desplegar». Puede resultar poco seguro colocar accesorios o piezas de recambio diferentes a los suministrados o recomendados por Silver Cross. Si este producto va a ser utilizado por otras personas aparte del propietario (p. ej. un abuelo o una niñera), enséñeles cómo hacerlo correctamente.

Cuidado y mantenimiento

Chasis - Compruebe siempre la silla por si hubiera indicios de desgaste. Lubrique periódicamente todas las partes móviles. Compruebe que haya total libertad de movimiento en todos los dispositivos de bloqueo. Pula el metal con un paño limpio y seco.

Componentes de tela y asiento - Para limpiar, pase una esponja por la zona con agua templada con jabón. Aclare bien con agua limpia para evitar manchas. Deje secar al aire, lejos del calor directo y de la luz solar fuerte. Es posible que pierdan algo de color con el uso diario. No los lave nunca a máquina, no los seque en la secadora, no los planche ni utilice lejía.

Garantía

Todos los productos de Silver Cross incluyen una garantía de 12 meses contra defectos de fabricación, siempre que el producto se utilice correctamente de acuerdo con el manual de instrucciones.

Lea detenidamente estas instrucciones antes de utilizar su nuevo producto Silver Cross y consérvelas para consultarlas en el futuro.

Примечания по безопасности

Этот продукт называется: Zest

Вы приобрели высококачественное изделие компании Silver Cross. Оно соответствует требованиям стандартов BS EN1888:2012 и при надлежащем использовании и уходе будет безотказно служить вам. Если, тем не менее, с изделием возникнут какие-либо проблемы, обращайтесь за помощью в магазин Silver Cross по месту приобретения коляски.

ВНИМАНИЕ!

Данное изделие пригодно для детей от рождения и до 25 кг

Для новорожденных рекомендуется использовать наиболее наклонное положение люльки.

Никогда не оставляйте ребенка без присмотра.

Прежде чем использовать коляску, убедитесь, что задействованы все фиксаторы.

Раскладывайте и складывайте изделие на удалении от ребенка во избежание травм.

Не давайте ребенку использовать изделие в качестве игрушки.

Всегда используйте входящие в комплект коляски ремни.

Данное изделие не предназначено для бега или катания на роликах.

При размещении ребенка в коляске или его извлечении необходимо привести в действие стояночный тормоз.

Вещи, висящие на ручках и/или на обратной стороне спинки и/или боках коляски снижают ее устойчивость.

Не носите с собой более одного ребенка в этой коляске.

Не позволяйте другим детям вставать на задний тормоз или использовать его в качестве приступки.

Не используйте приступки сторонних производителей.

Используйте только аксессуары, одобренные компанией Silver Cross.

Следует использовать запасные части, произведенные / рекомендованные компанией Silver Cross.

В случае поломки, деформации или отсутствия отдельных деталей использовать изделие нельзя.

Осторожно! Регулируя коляску, следите за тем, чтобы ребенок не приближался к ее подвижным деталям.

Не позволяйте ребенку самостоятельно садиться в коляску и вылезать из нее, поскольку он может получить травму или сломать коляску.

Никогда не оставляйте ребенка в коляске с полностью установленным дождевиком кроме случаев обычного использования коляски на улице.

Вы несете ответственность за безопасность вашего ребенка.

Сиденье совместимо только с Zest Рамой

Вместимость корзины: 2 кг

Ребенок должен быть обязательно пристегнут ремнями безопасности, соответствующими стандарту BS6684. Для крепления дополнительных ремней в конструкции люльки предусмотрены D-образные кольца. Они расположены на стандартных ремнях безопасности рядом с точками их крепления к раме сиденья.

Регулируя положение деталей коляски, всегда держите ее за сиденье. При этом должен быть задействован тормоз коляски. Складывая и раскладывая коляску, не прикладывайте излишних усилий: вы можете ее повредить. Внимательно прочтите инструкции по складыванию и раскладыванию коляски. Использование аксессуаров и запасных деталей, не поставляемых и не рекомендованных компанией Silver Cross, может быть опасным. Если люльку использует другой человек (например, бабушка, дедушка или няня), обязательно объясните этому человеку, как правильно ее использовать.

Уход и обслуживание

Рама – всегда проверяйте коляску на предмет износа. Регулярно смазывайте все подвижные детали. Проверьте, свободно ли работают все фиксаторы. Металлические части протирайте сухой, чистой тканью.

Детали из ткани и сиденье – для очистки деталей протрите губкой, смоченной теплой водой с мылом. Тщательно ополосните чистой водой, чтобы удалить остатки мыла. Просушите детали коляски в стороне от источников тепла и прямых солнечных лучей. Со временем ткань может немного выцвести в процессе повседневного использования. Не стирайте и не сушите детали коляски в стиральной машине, не гладьте и не отбеливайте их.

Гарантия

На всю продукцию Silver Cross действует гарантия сроком 12 месяцев, покрывающая случаи производственного брака, при условии использования изделия в соответствии с инструкциями.

Перед использованием нового изделия Silver Cross внимательно прочтите данную инструкцию и сохраните ее для использования в будущем.

安全注意事项

该产品被称为：Zest

本品是Silver Cross生产的一款优质产品。本品符合BS EN1888:2012 如果合理使用和维护得当，本品将经久耐用。如果您的产品出现任何问题，请联系Silver Cross零售商，零售商将采取适当措施。

警告：

本产品适用于从新生儿至25公斤重的婴儿。

建议对新生儿使用斜度最大的位置。

婴儿乘坐时必须有人看护。

使用前确保所有锁定装置均处于锁定状态。

为了避免伤到婴儿，在折起或打开本产品时请不要让孩子靠近。

不可让婴儿摆弄本产品。

始终使用约束防护装置。

使用前检查婴儿车的车身、座椅或汽车座位连接装置是否牢固。

本产品不适合奔跑或滑行。

在将婴儿抱进、抱出婴儿车时要启用刹车装置。

婴儿车手柄和（或）座椅靠背和（或）婴儿车两侧如果有任何负重均会影响婴儿车的稳定性。

不要随身携带一个以上的孩子在这种折叠式婴儿车。

不要让其他孩子站在后闸上并将其用作婴儿车后踏板。

不要附加第三方婴儿车后踏板。

不得使用未经Silver Cross认证的配件。

只可使用Silver Cross提供或推荐的备用件。

如有部件出现破损、撕裂或丢失，请勿使用。

小心：在调节时不要让孩子靠近移动部件。

请勿让幼儿自己爬进或爬出婴儿推车，因为这将伤到幼儿或损坏婴儿推车。

除正常户外使用外，切勿在完全安装雨篷状态下将孩子留在婴儿推车中。

保护婴儿的安全是您的责任。

座椅装置仅适用于：Zest 底盘

购物篮承重：2公斤

婴儿应始终系好符合BS6684标准的安全带。同时提供“D”形环，用来安装加固安全带。这些“D”形环位于现有安全带与座椅框架的连接处附近。

进行调节时始终握住座椅。要确保刹车装置已启用。如果您在收起或展开折叠式婴儿车时遇到困难，请勿强行操作，否则会造成损毁。仔细阅读“收起或展开”说明。除SilverCross提供或推荐的产品外，安装其他配件或备件可能会有安全隐患。如果其他人（如爷爷奶奶、保姆）要使用婴儿车，请向其演示正确操作方法。

婴儿车手柄和（或）座椅靠背和（或）婴儿车两侧如果有任何负重均会影响婴儿车的稳定性。保护婴儿的安全是您的责任。将婴儿抱进、抱出婴儿车时要启用刹车装置。只可使用Silver Cross认证的配件和备用件。

维护与保养

底盘——要经常检查折叠式婴儿车是否有磨损迹象。定期润滑所有运转零件。检查所有锁定装置的运动灵活性。用干净、干爽的抹布擦拭金属部件。

织物和座椅——清洁时用海绵蘸温热肥皂水擦拭。之后用清水冲洗以免留下污迹。自然晾干，请勿将产品置于直接热源和日照强烈的地方。随着长期使用，产品可能出现某种程度上的褪色。请勿机洗、烘干、熨烫或漂白。

保修

在依据说明书正确使用产品的情况下，所有Silver Cross产品对工艺质量问题保修期为12个月。

使用新购Silver Cross产品前请仔细阅读这些说明，并注意保存以备参考。

Silver Cross®

THE BEST START IN LIFE

Silver Cross (UK) Ltd, Micklethorn, Broughton, Skipton, North Yorkshire, BD23 3JA

silvercrossbaby.com